

TECHNICAL BULLETIN – TB192

SMOOTHING CEMENT - MOISTURE BARRIER SYSTEMS



Date, Monday, 8 May 2017

INTRODUCTION & SCOPE

Concrete Substrates come in many different forms – new concrete, old concrete, on grade, below grade, suspended floors. These floors then require application of many varied types of bonded floor coverings – parquet, rubber flooring, sheet & tile vinyl flooring, direct stick carpet, cork etc.

The success of installing new floor coverings requires the selection of good quality material, an experienced and capable tradesman and evaluation of the condition of the concrete subfloor to accept the new flooring.

The physical condition of the structurally sound concrete subfloor – scratch hardness, smoothness, flatness can be visually inspected, evaluated then specified for a repair/remodelling procedure. Moisture content of the concrete, however, is an unseen condition, which requires testing preferably using hygrometer testing equipment as per AS1884.2012 or AS2455-2007.

The standards put the responsibility back on to the installer to confirm the suitability of a subfloor before laying the flooring materials. Testing for moisture content can produce varying readings, depending on temperature, humidity, air conditioning/heating at time of testing, and in many cases may require professional evaluation to properly analyse the test readings.

At a glance, the concrete subfloor may appear dry and only after being sealed with an impervious floor covering does a moisture problem surface. The rectification costs typically exceed three times the original placement cost. Moisture problems also increase the likelihood of issues with alkaline pH attack which cause degradation of the vinyl adhesive and in some cases can also attack the floor covering itself.

For more detail on these topics refer ARDEX Technical Bulletins TB040 and TB081.

SOLUTION

The ARDEX Moisture Barrier System which uses ARDEX WPM300 HYDREPOXY provides protection against capillary and hydrostatic moisture on structural concrete substrates. This water based epoxy membrane has a low moisture vapour transmission of only 7.8g/m²/24 hours, which is well under the requirements of AS2870 (the standard for damp-proofing of floors).

The Moisture Barrier is protected by a minimum 3 – 4mm layer of ARDEX Self Smoothing Cement which provides a smooth hard flat surface for the conventional installation of floor coverings.

The epoxy base for ARDEX WPM300 HYDREPOXY is a product that has been available for many years in Australia and has a tried and proven track record. The total system has been designed to be as cost efficient as possible, knowing the parameters we have to work with and many projects have been done this way.

SUBFLOOR PREPARATION

1. Proper preparation of the surface is the most important factor in achieving this bond. The steps and methods required to properly prepare the subfloor depend on the condition of the subfloor and its surface.



2. All weak, loose powdery surfaces of the subfloor must be removed back to a solid, clean open porous matrix of the concrete. Mechanically remove this weak surface either by scarifying, shotblasting or diamond shaving/grinding. Shotblasting is the preferred cleaning procedure.
3. Shotblast (using a dust free system) to remove all adhesive and laitance and expose the clean sound porous matrix of the substrate. This will require two or more passes, but it is imperative that a perfectly clean surface is exposed. All edge shot-blasting and grinding should be totally finished before the final pass of the blast procedure occurs.
4. Allow all shot-blasted areas to free stand for a minimum of thirty hours with no traffic on it at all. This will help ensure that if there is any residual moisture vapour entrapped in the surface to evaporate before the surface is sealed. If for some reason there has to be foot traffic on the prepared surface during this time, extreme care must be taken to ensure no dirt or soil contamination takes place via shoe or boot migration.
5. Special emphasis must be given to ensure total preparation is done in hard to get at areas and around doorways etc.
6. Expansion and Construction joints to be individually noted and repair procedure to be evaluated and individual cost advised only when exposed after shot-blasting and scabbling.
7. All cracks to be noted by the contractor for future reference, and structural cracks shall be brought to the attention of the engineer before continuing.
8. Remove all dust and debris and vacuum thoroughly to provide an open porous matrix of the concrete.

ARDEX Technical Bulletins TB041 examines preparation issues, and TB037 & TB039 discuss the implications that can result from poor preparation.

INSTALLATION OF ARDEX MOISTURE BARRIER

9. Thoroughly mix the individual Part A & B components of the ARDEX WPM300 then mix the components in equal volumes to achieve a homogeneous mix.
10. Apply the total of two coats of the mixed epoxy with a final total coverage of 1.5m² per litre to give a final dry film thickness (DFT) of 0.3mm (300µm).

First coat to be applied at 3.5m² per litre (0.29 litre/m² @250µm WFT)

Second coat at 2.5m² per litre (0.4 litre/m² @400µm WFT)

NOTE: THESE ARE IN OPPOSITE ORDER TO THE INSTRUCTIONS IN TB006

Extreme care must be taken to apply the coats in different directions to ensure that there are no windows left in the second coat and absolutely no pinholes in either coat. Pinholes lead to development of localised areas of high moisture and humidity under the floor covering.

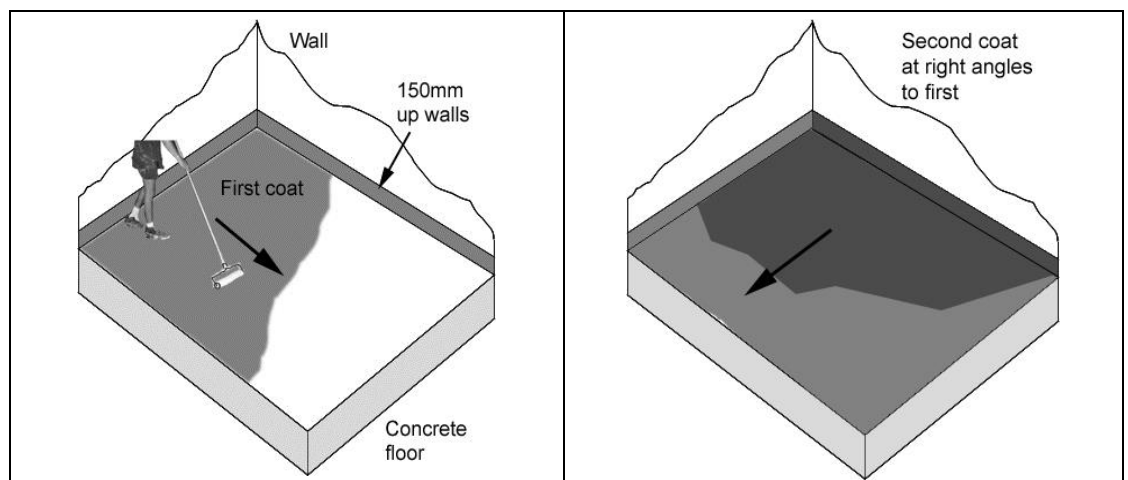

The coats are applied at 90 degree angles to obtain a complete coverage.

Note: It is important to obtain the coverage per coat as specified above, to ensure an adequate coating thickness for optimum performance. Correct coverage can be achieved by marking out the area to correspond to the litres mixed i.e. 1 coat @ 2.5m²/litre – 1 x 20 litre kit covers 50m² (nominally 20 litres covers 60m² at 0.3mm DFT for one coat).

Mark out 50m², then mix up the 20 litre kit (Part A & B), squeegee out the 20 litres to the entire 50m² (ensuring an even coat throughout). Then using a medium length nap roller, roll the ARDEX WPM300 into the surface of the concrete. The same procedure although at a different coverage rate is repeated for the second coat.

Calculate then accurately measure out the quantity of ARDEX Moisture Barrier corresponding to the coverage rate required

e.g. 50m² @ 3.5m² per litre

$$\frac{50}{3.5} = \sim 14.3 \text{ litres}$$
 (i.e. 7.15 litres of PART A and 7.15 litres of PART B)
 (Say 7.2 litres of each to allow for waste)

This method of installation ensures exact quantities are budgeted and used on site as no more than 10% batching error is acceptable with epoxy materials.

11. Depending on the ambient temperature, it is important *that a minimum of three hours have elapsed between coats*. To achieve a bond for the subsequently applied smoothing cement, sand is broadcast over the second coat of WPM300 **whilst still wet**. The sand shall be kiln dried washed quartz sand with a preferred particle size of 0.3mm. The recommended coverage is 700gms/m² over 90% of the area.

Note: that at temperatures below 10⁰C and at air relative humidity exceeding 85% the cure of the epoxy will be retarded.

12. The following day, excess sand and broomed and vacuumed off the surface prior to the installation of the smoothing cement.

Important Detailing Considerations

13. The moisture barrier is to be continued up all concrete, rendered and other vertical surfaces to a distance of 150mm above the floor height. (Moisture can move sideways from other areas as well as vertically from the subfloor).

Note: All wall-to-wall, wall-floor, floor waste junctions, penetrations and all other mobile joints shall be reinforced with the 190mm wide x 44gsm woven fabric tape (ARDEX Deckweb).

The moisture barrier is applied to all penetrations as well as up the walls to a height of 150mm. All angles and penetrations to be reinforced with ARDEX Deckweb.

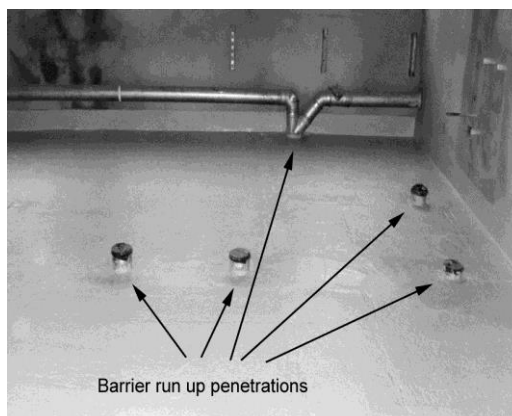

14. A bond-breaker is to be used where hydrostatic pressure *is not an issue* at these mobile joints. This comprises a bead of neutral cure silicone sealant or polyurethane sealant applied in the corner. Ensure the sealant is fully cured before moisture barrier application.

Note: WPM300 is a Class I type liquid membrane to AS3740 so is not intended to be used as a primary wet area waterproofing in the same way as a Class III membrane.

15. Where hydrostatic pressure is present as opposed to simple dampness, a fillet cove using ARDEX BR345 (>10mm) or ARDEX BR120FC (1-3mm) will provide a smooth transition and eliminate sharp corners at walls. This can also be done with WPM300-sand/cement mix.
16. Depending on the ambient temperature, it is important *that a minimum of three hours have elapsed between coats*. Although full cure is seven days at 25°C 50% RH, the next procedure can take place once the surface is scratch hard (approximately 12 – 24 hours @ 20°C) as this will not inhibit the curing process.

Note: that at temperatures below 10⁰C and at air relative humidity exceeding 85% the cure of the epoxy will be retarded, and high surface pH (>11.5-12) can affect the performance of the epoxy.

17. In the case of **non-active** cracks these should be “V” gouged out to allow for sufficient filling of the crack. Prime with mixed ARDEX WPM300 and then fill with a slurry made from ARDEX WPM300 mixed with 25% by volume Portland cement. Keep the repair medium down approximately 2mm below the surface and allow to cure for 24 hours prior to further work.

Smaller hairline cracks can be treated by the application of the moisture barrier with a brush to a width of 100mm either side of the crack, and then whilst still liquid, ARDEX Deckweb tape is worked into the moisture barrier with a metal ribbed roller. A second coat of the moisture barrier is then applied with a brush over the embedded tape.

Note: these cracks are a structural defect and they may eventually mirror through to the subsequent floor coverings. ARDEX suggests all cracks to be noted on a floor plan for reference purposes. All cracks should be referred to a suitably qualified Structural Engineer for assessment, as active cracks will re-open or close, and produce show through, result in moisture problems or even damage resilient flooring. Active cracks require remedial works such as epoxy-metal pinning or as recommended by the engineer.

18. Where cracks are identified as potentially active, repairs can be made under the advice of the engineer, using the ARDEX concrete repair injection system based around ARDEX RA88, RA142, RA144 and RA146 epoxy repair resins.
19. In some cases where walls have been taken out and then the floor areas has been concrete filled, these may have to be scabbled out to a depth of 50mm or more and back filled with a special concrete that contains ARDEX WPM300 mixed into the concrete slurry. The mix design for the water resistant concrete by volume is:

1 Part mixed ARDEX WPM300 epoxy

1 Part Portland cement

1-1.5 Parts washed dry sand ~0.3mm

1 Part washed dry aggregate 3-8mm or 2-5mm

(The sand and aggregate above can be replaced with 2-2.5 parts of ARDEX A38 mixed aggregate).

Alternatively the water resistant ARDEX BR120FC or ARDEX BR345 repair mortars can be used (BR120FC – 3mm or BR345 10-80mm thick).

APPLICATION OF SMOOTHING CEMENT



Note: Compliance to Building Code of Australia requires that ARDEX Moisture Barrier “Must be covered or protected from abrasion by vehicular or pedestrian traffic”

20. The recommended smoothing cements can be any of the following products, ARDEX K15, K12, K120, K55, K220, K10R8 or Arditex NA.
21. The self smoothing cement shall be installed at 3 – 4mm which provides the necessary protection and a smooth flat cement surface for the conventional installations of floor coverings.

Note: Applications of smoothing cement less than 3mm puts the membrane at risk of possible damage during progress sanding or cutting operations during vinyl installation. Insufficient thickness will also not provide a porous surface suitable for certain types of vinyl or parquet adhesive.

21. Where special situations such as parquet or direct stick flooring are to be used, it is recommended that only ARDEX K15 mixed with ARDEX E25; or ARDEX K55 smoothing cement are to be used.
22. The smoothing cements can typically be walked on from 2 – 4 hours at 20°C depending on product.
23. Underlayment can accept floor covering material after around 90 minutes for K55, 16-18hrs for K15 or K12 and from 24-48 hours at 20° C for the other products. Refer to the individual product datasheets for specific recommendations.
24. Air-conditioning to stay on during the time that the work is being carried out.
25. Resilient flooring adhesive only to be used which is recommended by the vinyl manufacturer. Tack off time to be strictly adhered to any pre-priming done where recommended. ARDEX recommended adhesives include;
 - AF142 for vinyl planks and tiles
 - AF143 or AF172 for vinyl planks, tiles and underlays
 - AF158 for VCT
 - AF152 or AF178 for sheet vinyl
 - AF241 for carpets
 - AF239 or AF236 for carpet tiles

TREATMENT OF FLOOR MOVEMENT JOINTS

Expansion joints shall be continued through the ARDEX WPM300 and underlayment.

26. The expansion joints shall be pre-filled with backer rod or similar to prevent leakage of the underlayment.
27. Apply the moisture barrier and underlayment over the joint. Ensure the location of the joint is clearly marked on adjacent fixtures.
28. Once the underlayment has sufficiently hardened, saw cut through the underlayment to expose the joint.
29. Remove all underlayment from the joints and ensure the vertical saw cuts within the joint are clean, dry and free of dust, dirt etc.
30. Apply ARDEX Moisture Barrier to the vertical edges of the joint and after hardening install a suitable flexible polyurethane (ARDEX RA030 and ARDEX RA040), structural silicone or epoxy jointing system.



As per steps 26-27, the joint has been cleaned and filled with a backer rod. The Moisture Barrier has been applied followed by the underlayment.

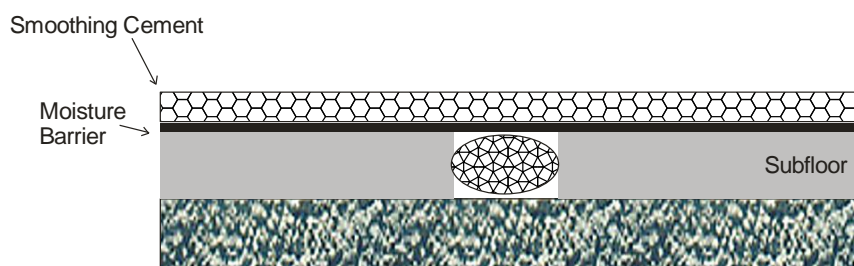

As per step 28, when underlayment is fully cured, it is saw cut through to the FULL WIDTH of the JOINT.

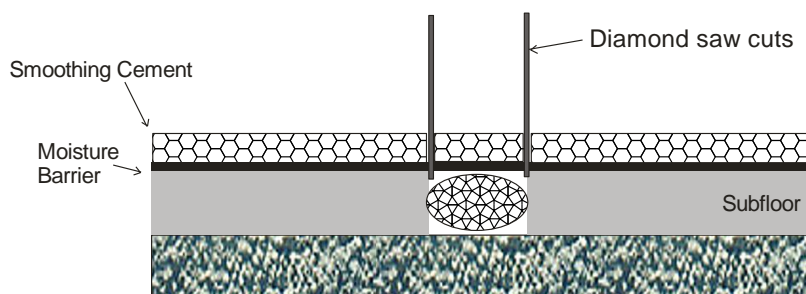

As per step 29 the material from the saw cut has been removed.

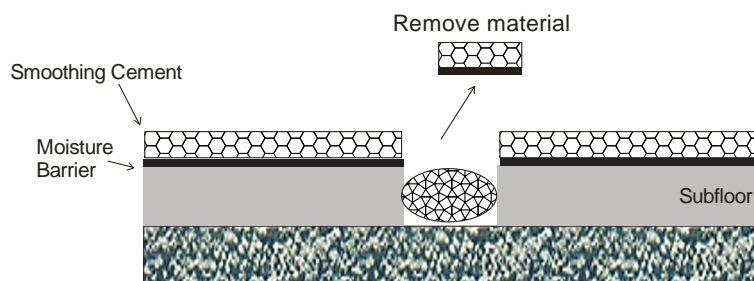

As per step 30 Moisture Barrier is painted thoroughly down into the joint. A suitable flexible sealant system is then installed (may include mouldings or metal extrusions)

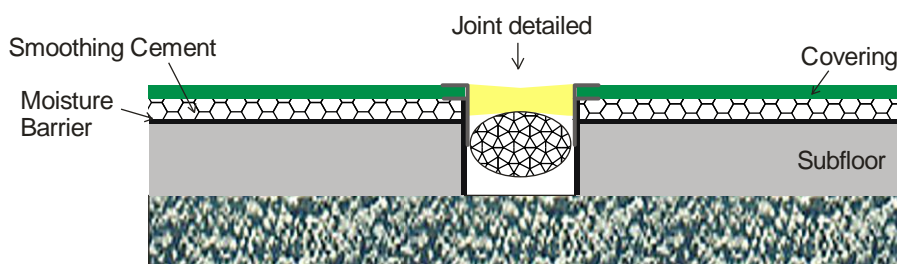

WARNING

Failure to install the recommended dry film thickness of the moisture barrier can result in reduced performance and increased water vapour transmission. Thin coats applied to 'cut costs' are a false economy and must be avoided. Poor application and thickness problems have led to failures and problems with moisture affecting the overlying floor covering.

GLOSSARY

AS3958.1-2007 Ceramic tiles

Part 1: Guide to the installation of ceramic tiles.

Bond breaker – A system that prevents the membrane bonding to the substrate, bedding or lining.

Bulk filled – A liquid or paste smoothing cement which has had aggregate or coarse sand added to it to add bulk and alter the handling properties (usually to reduce flow).

Feather edge – where the smoothing cement is wedged done a fine and thin transition, typical 1mm or less in thickness.

Finger tight – The mortar is firm to touch and does not easily deform or slump, but is still soft enough to work and shape with a trowel or a dampened trowel.

Granolithic topping – A type of “sand”-cement screed where the sand is actually a mixture of sand (0.05-2mm size) and fine gravel between 2-5mm normally which is mixed with cement and laid in the same sort of way as a normal sand-cement screed. The range of particle sizes makes these screeds stronger than the typical fine sand only screeds.

Leveller– also called smoothing cement, floor levelling cement, topping or the standard term underlayment. These are typically poured liquids but can also be mortar pastes.

Mechanical method-As defined in AS1884-2012 is,

“1.3.15 Mechanical means

‘Mechanical means’ is the process of surface preparation performed by application of applied physical forces to the substrate surfaces to remove contamination. For the purposes of installations on concrete this refers to the use of diamond grinders, scarifiers and captive shot blasters. For smaller areas this can include chippers and nail gun type scabblers. When installations are to be performed on timber floors ‘mechanical means’ refers to floor sanders. Regardless of the means used the final process in a mechanical preparation is vacuum cleaning.”

Moisture Barrier - This term refers to a waterproofing membrane which is used to prevent rising moisture from the substrate. It can be either liquid water or water vapour. These can fall under AS4858/AS740 or AS2870.

Resilient flooring – Sheet and tile coverings in all forms which includes flexible PVC, semi-rigid PVC, linoleum and rubber.

Waterproof membrane – The term membrane is the general covering name for all sorts of waterproofing, but in this case is taken to mean flexible membranes compliant with AS4858 and designed to stop water from above the flooring penetrating.

Wet areas – An area within a building supplied with water from a water supply system, which includes bathrooms, showers, laundries and sanitary compartments and excludes kitchens, bar areas, kitchenettes or domestic food and beverage preparation areas. (From AS3740-2010).

IMPORTANT

This Technical Bulletin provides guideline information only and is not intended to be interpreted as a general specification for the application/installation of the products described. Since each project potentially differs in exposure/condition specific recommendations may vary from the information contained herein. For recommendations for specific applications/installations contact your nearest ARDEX Australia or ARDEX New Zealand Office.

DISCLAIMER

The information presented in this Technical Bulletin is to the best of our knowledge true and accurate. No warranty is implied or given as to its completeness or accuracy in describing the performance or suitability of a product for a particular application. Users are asked to check that the literature in their possession is the latest issue.

REASON FOR REVISION - ISSUER

Replacement of B34/B36 with BR120FC and BR345. Inclusion of K120, K220, RA142, RA144, RA146, RA030 & RA040. Removal of references to K009 and K11. Addition glossary.

REVIEW REQUIRED

36 months from date of issue.

Technical Services 1800 224 070. email: technicalservices@ARDEXaustralia.com
Australia <http://www.ARDEXaustralia.com>

NSW-HO 61 2 9851 9100, **QLD** 07 3817 6000, **VIC** 03 8339 3100, **SA/NT** 08 8406 2500, **WA** 08 9256 8600
Customer Service and Sales 1300 788 780

New Zealand Christ Church 64 3373 6900, Auckland 9636 0005, Wellington 4568 5949
Technical Inquiries NZ 0800 2 ARDEX New Zealand <http://www.ARDEX.co.nz>

Web: Corporate: <http://www.ARDEX.com>